

# Smart Touchscreen Weighing

## Innovation Meets Durability



**Rich functionality, superior quality and future-proof technology: FreshBase Plus Line is the new range of scales for grocery retailers who are looking to move into the performance class of convenient touchscreen weighing.**

With accurate weighing, fast printing and innovative technology, FreshBase Plus brings convenient and intuitive touchscreen operation to sales counters, backrooms and self-service weighing areas. FreshBase Plus can also run third party software to enable seamless checkout functionality to specialty shops.

**METTLER TOLEDO**

# FreshBase Plus

## Enhanced customer experience

With FreshBase Plus, retailers are choosing a thoroughly future-proof investment decision. Operators enjoy smooth processes, fast weighing feedback and rich functionality. Robust design and high-quality components boost operational uptime and lengthen equipment life cycle, even under the harshest conditions.

### Highly Functional



With its intuitive GUI, powerful search and smooth operation, training new operators is easy and efficient. Your IT department is fully supported with customizations, remote access and other advanced features that enhance asset management, in-store advertising and operations.

### Superior Quality



Durable even in the harshest conditions: FreshBase Plus eases through printing, weighing, and touchscreen control without losing quality. Designed with ultimate hygiene in mind, pests and cockroaches are unable to penetrate the equipment and damage internal components.

### Future-Proof Technology



Enhance customer loyalty and satisfaction. The modern, sleek design with large display improves any store's image. Optional features like second printer and camera module help optimize performance.

### Ergonomic design

The capacitive touchscreen can be adjusted to best suit the ergonomic needs of the operator, making operation more convenient. The high-resolution, large display improves screen visibility and usage.

### Bright customer display

The large customer display with LED-backlit technology has a high degree of angle stability, no glare and excellent contrast to ensure the best visibility and legibility. Digital advertising content and cross-promotions on the screen can help boost profits.

### Durable housing

The aluminium casing and tower are strong and stable. Scuffs and marks remain virtually unseen, and the robust stability ensures accuracy every time. The internal core modules are protected from dirt, moisture and damage.

### Rapid roll change

Changing the roll is completely hassle-free, meaning less wait times for customers. The 2-inch label printer and ticket printer quickly prints all purchased items on the paper. Larger rolls are accommodated, reducing the need to change rolls.

Find more information at:

► [www.mt.com/FreshBase-Plus](http://www.mt.com/FreshBase-Plus)

### FreshBase Plus Line – The Smart Access to Touchscreen Weighing

- Touchscreen convenience plus high-performance scale application
- Rapid weighing process due to the interactive touchscreen user prompts
- High level of functionality and robustness of the reliable and rich METTLER TOLEDO scales software
- Simple integration into existing processes and environments (e.g. tools, inventory management)
- Green MT: Energy-saving and resource-effective embedded system
- High-quality components for a long life cycle



# Technical Data

## FreshBase Plus Line

### Operator Display

- 15.6 inch capacitive touchscreen
- Screen resolution: 1920x1080 pixels
- Tilt angle adjustable (stepless)

### Customer Display

- 7-inch customer display
- Tilt angle fixed
- Screen resolution: 1024x600 pixels

### CPU

RK 3288 Quad-Core 1.8GHz

### Printer

- Thermal printer for receipts, labels
- Printing speed: up to 125 mm/s
- Print resolution: 8 dots/mm
- Printable width: 56 mm
- Roll diameter: max. 120 mm

### Data Storage

- 2 GB DDR3
- 16 GB eMMC

### Interfaces and protocols

- Ethernet interface (10 / 100M, 1000M Compatible)
- 1 x serial RS232 interfaces (Optional)
- 1 x RJ11 interface for controlling the cash register drawer
- 2 x USB 2.0 connections (Bottom of tower)
- 2 x USB 2.0 connections (Side of tower) (Optional)
- 1 x USB OTG connection
- IEEE 802.11 a/b/g/n/ac standard

### Operating system

- MT Smart OS Embedded

### Power Supply

- 100 – 240 V AC, 50 / 60 Hz

### Casing

- High stability due to aluminium die-cast casing
- High stability due to aluminium tower
- Shock-resistant and imbued ABS polymer display casing and tower cover



FreshBase U2



FreshBase U3

Weighing Range	3 kg / 6 kg	6 kg / 15 kg	15 kg / 30 kg
Partition	1 g / 2 g	2 g / 5 g	5 g / 10 g
Minimum weight	20 g	40 g	100 g

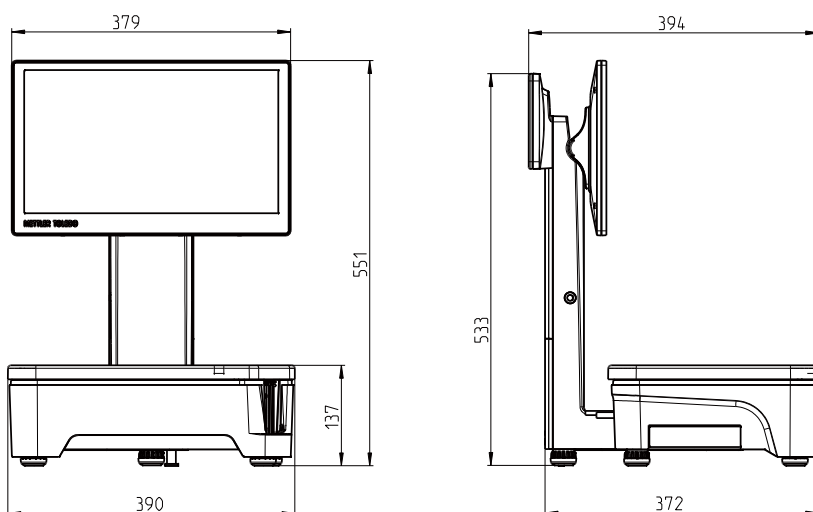

[www.mt.com/retail](http://www.mt.com/retail)

For more information



Mettler-Toledo

Subject to technical changes.  
© 2021 Mettler-Toledo